

s. 93 NPT Downstream Exhaust

full port 1/4"-2"
hot forged brass ball valves



Featuring patented tamper-proof lockable handle that has no equal in the market.

RuB s.93 range exhausts automatically and continuously downstream air pressure as soon as turned in the closed position.

Valve is lockable in the closed position only, according to Part. 1910.147 safety OSHA (USA) requirements allowing safe maintenance of the air-supplied equipment; when valve is open, one simple 90° turn of the handle shuts flow immediately.



We care for those you care for.

Quality

- No metal-to-metal moving parts
- Handle clearly shows ball position
- Silicone-free lubricant on all seals
- Chrome plated brass ball for longer life
- Travel stops on body to avoid stresses at stem

Body

- Hot forged sand blasted, unplated brass body and cap sealed with Loctite or equivalent thread sealant
- The valve body includes a tapped downstream depressurization venting outlet to direct exhaust air and assemble mufflers for noise control
- Finest brass according to EN 12165 and EN 12164 (formerly DIN 17660 and UNI 5705-65) specifications

Stem

- Blowout-proof nickel plated brass stem
- Pure virgin PTFE adjustable packing gland and reinforced washer for lower torque and easy maintenance

Working Pressure

- 200 PSI
- non-shock cold working pressure

Options

- AISI 430 stainless steel handle
- Non-locking Geomet® carbon steel lever handle
- ISO 7/1 BSPT Taper threads
- EN 10226-1, ISO 228 Parallel Threads



Flow

- Full port to DIN 3357 for maximum flow

Thread

- NPT taper ANSI B.1.20.1 female by female threads

Handle

- Geomet® carbon steel lockable handle patent n. 7074-B/90 with thick PVC dip coating. Handle coating offers both thermal and electrical protection
- Handle removable with valve in service

Seals

- Glass filled pure PTFE self-lubricating seats with flexible-lip design

Operating Temperature

- +15°F / +210°F Warning: freezing of the fluid in the installation may severely damage the valve

Upon request

- AISI 316 stainless steel ball and/or stem
- Custom Design
- T-handle

Approved By:



NOTE: Approvals apply to specific configurations only



5371 12th Avenue East - Shakopee MN 55379-1896 U.S.A.
Ph: +1 (952) 857 1114 - Fax: +1 (952) 857 1118
info@rubinc.com - www.rubinc.com



s. 93 NPT Downstream Exhaust

full port 1/4"-2"
hot forged brass ball valves

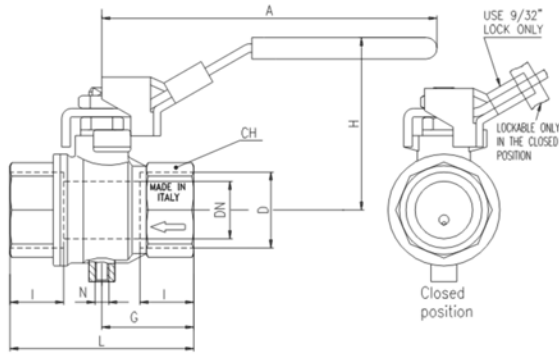
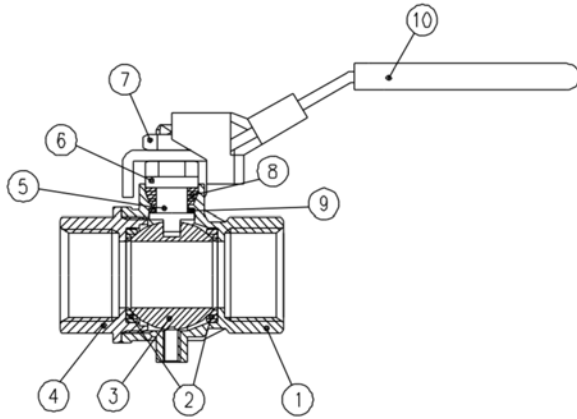

PART DESCRIPTION	Q.TY	MATERIAL
1 Unplated body	1	CW617N
2 Seat	2	PTFE glass filled 5-15%
3 Chrome plated ball	1	CW617N
4 Unplated end cap	1	CW617N
5 Nickel plated stem packing gland design	1	CW617N
6 Nickel plated gland nut	1	CW617N
7 Geomet® nut	1	CB4FF
8 Packing gland seal	1	PTFE
9 Washer	1	PTFE carbon filled 25%
10 Light blue PVC coated Geomet® steel lockable handle	1	DD11

Code	S93B41	S93C41	S93D41	S93E41	S93F41	S93G41	S93H41	S93I41
D (inch)	1/4	3/8	1/2	3/4	1	1 1/4	1 1/2	2
DN (inch)	0.314	0.393	0.590	0.787	0.984	1.260	1.575	1.969
I (inch)	0.472	0.472	0.610	0.669	0.826	0.906	0.906	1.043
L (inch)	1.771	1.771	2.322	2.519	3.188	3.661	4.016	4.764
G (inch)	0.885	0.885	1.161	1.259	1.594	1.831	2.008	2.382
A (inch)	3.759	3.759	3.759	4.574	4.574	6.161	6.161	6.161
H (inch)	1.906	1.906	2.014	2.364	2.530	3.148	3.396	3.661
CH (inch)	0.787	0.787	0.984	1.220	1.574	1.929	2.126	2.697
N	10-32 UNF						1/4" NPT	

DN shows the nominal flow diameter. Actual flow diameter complies with full port DIN 3357 part 4.

Ask for additional information on the whole range of RuB valves and consult with your supplier for special applications.

Pressure - Temperature Chart

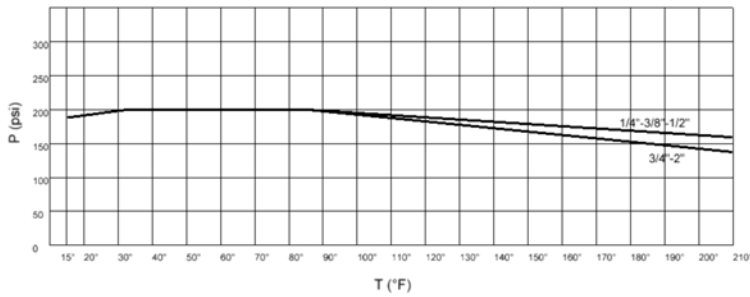

Pressure Drop Chart

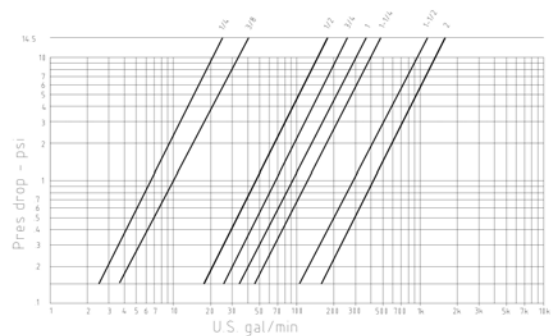

The company reserves all rights for the information contained herein. Products may be changed at any time without notice. Any undated reference to a code or standard shall be interpreted as referring to the latest edition. RuB and logo are registered trademarks of RuB-Rubinetteria utensilerie Bonomi. Others logos are property of respective owners.



5371 12th Avenue East - Shakopee MN 55379-1896 U.S.A.
Ph: +1 (952) 857 1114 - Fax: +1 (952) 857 1118
info@rubinc.com - www.rubinc.com

