



Master Pneumatic-Detroit, Inc.

6701 18 Mile Road • Sterling Heights, MI 48314 • Phone: (586) 254 1000 • Fax (586) 254-6055
Email: mp@masterpneumatic.com • Website: www.masterpneumatic.com

USE INSTRUCTIONS BELOW FOR “NRE” STYLE DRYER/FILTERS WITH FIXED SCREEN AND FILTER DISKS REPLACEMENT ELEMENT KIT

INSTALLATION INSTRUCTIONS FOR DRYER/FILTER MODELS 625-150 AND 832-550

REPLACEMENT ELEMENT KIT MODELS:
CD-625-NRE, MS-625NRE, CD/C-625NRE
CD-832NRE, MS-832NRE, AND CD/C-832NRE

WARNING — BEFORE SERVICING UNIT:

- Shut off air supply.
- Relieve the pressure from the dryer/filter by manually activating the drain unit on the bottom of the housing.

1. Remove the cover clamp (1) by turning the clamp knob in a counter-clockwise direction.
2. Gently remove cover (2), remove spacer assembly (37) and turn upside down.
3. Remove the middle screen (35) by rotating the screen in a counter-clockwise direction and then remove the used filter disks (34). (SEE ILLUSTRATION AT RIGHT)
4. Install new filter disks (34) by inserting over disk rod (33).
5. Replace the middle screen (35) by rotating in a clockwise direction.
6. Remove the used desiccant bag from the housing by lifting on the bag strap.
7. Inspect and clean the inside of the dryer/filter body.
8. Remove the plastic protective bag from the new desiccant bag.
9. Insert the new desiccant bag into the dryer/filter body making sure the desiccant bag strap is in an upward position (38). (SEE ILLUSTRATION AT RIGHT).
10. Install the spacer assembly (37) with the filter disks facing DOWN into the housing. (SEE ILLUSTRATION AT RIGHT).
11. Inspect the gasket (4) on the cover and replace if necessary.
12. Install cover (2) and clamp (1) and tighten to 45-55 in-lbs.
13. Open air supply to dryer/filter **SLOWLY**. Check cover for air leakage. If leakage occurs, shut off air supply, relieve pressure from unit by manually activating the drain unit on the bottom of the housing, and retighten clamp.
14. Record the date of desiccant bag change on yellow label supplied in Replacement Element Kit. Affix label to dryer/filter body.

NOTE: MAKE SURE AIR SUPPLY IS SHUT OFF BEFORE SERVICING DRYER/FILTER AND RELIEVE AIR PRESSURE BY OPENING THE DRAIN.

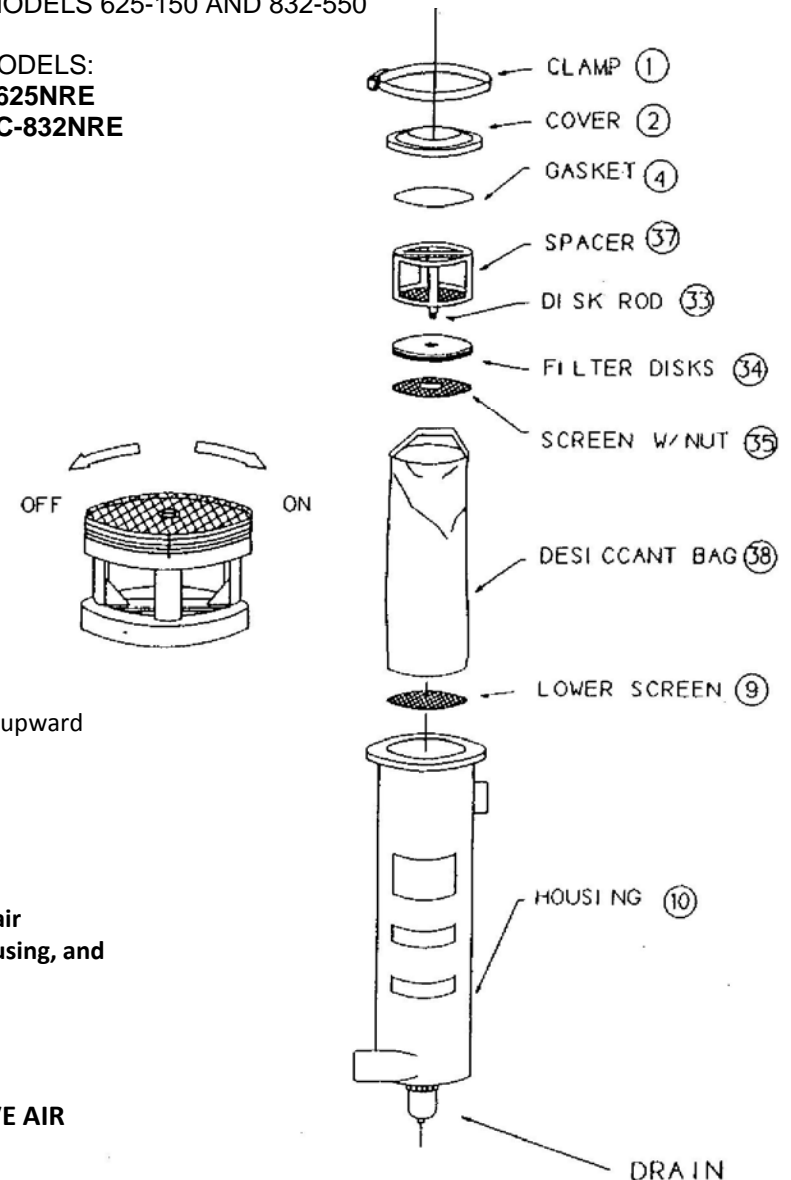



Master Pneumatic-Detroit, Inc.

6701 18 Mile Road • Sterling Heights, MI 48314 • Phone: (586) 254 1000 • Fax (586) 254-6055
Email: mp@masterpneumatic.com • Website: www.masterpneumatic.com

USE INSTRUCTIONS BELOW FOR “RE” STYLE DRYER/FILTERS WITH FIXED SCREEN AND FILTER DISKS REPLACEMENT ELEMENT KIT

INSTALLATION INSTRUCTIONS FOR DRYER/FILTER MODELS 625-150 AND 832-550

REPLACEMENT ELEMENT KIT MODELS:

CD-625-RE, MS-625RE, CD/C-625RE

CD-832RE, MS-832RE, AND CD/C-832RE

WARNING — BEFORE SERVICING UNIT:

- Shut off air supply.
- Relieve the pressure from the dryer/filter by manually activating the drain unit on the bottom of the housing.

1. Remove the cover clamp (1) and cover (2).
2. Remove the spacer (5).
3. Remove top screen (9), used filter disks (7), and middle screen (9).
4. Remove old desiccant bag (38)..
5. Inspect and clean the inside of the dryer/filter body.
6. Remove the plastic protective bag from the new desiccant bag.
7. Insert the new desiccant bag into the dryer/filter body making sure the desiccant bag strap is in an upward position (38). (SEE ILLUSTRATION AT RIGHT).
8. Replace the middle screen (9), the new filter disks (7), and top screen (9).
9. Install the spacer (5).
10. Inspect the gasket (4) o the cover for damage and replace if necessary.
11. Install cover (2).
12. Install clamp (1) and tighten knob to 45-55 In-lbs.
13. Open air supply to dryer/filter **SLOWLY**. Check cover for air leakage. If leakage occurs, shut off air supply, relieve pressure from unit by manually activating the drain unit on the bottom of the housing, and retighten clamp.
14. Record the date of desiccant bag change on yellow label supplied in Replacement Element Kit. Affix label to dryer/filter body.

NOTE: MAKE SURE AIR SUPPLY IS SHUT OFF BEFORE SERVICING DRYER/FILTER AND RELIEVE AIR PRESSURE BY OPENING THE DRAIN.

